

### Piston Seal Replacement

**WARNING:** Before performing any repairs on Cengar tools ensure the tool is in the off position and any air-lines have been detached.

Over the course of time the Piston Seal & Wear Strip can become worn out by general wear and tear.

To replace the Piston Seal & Wear Strip follow the instructions below.

Additional information and instructional videos can be found at [www.cengar.com](http://www.cengar.com)

#### 1. Remove the lifting bracket screws.

Using an Allen key and spanner, remove the two screws from the pallet spreader to release the lifting bracket and board retainer.

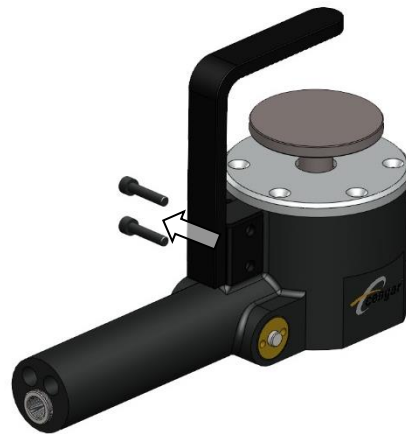

#### 2. Remove the lifting bracket.

Pull the lifting bracket from the rear of the machine and set to one side.

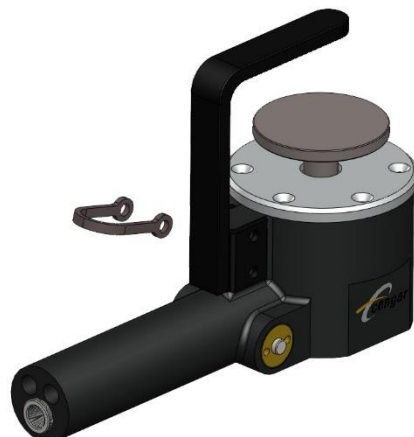

**3. Remove the board retainer.**

Pull the board retainer from the rear of the machine to remove it.

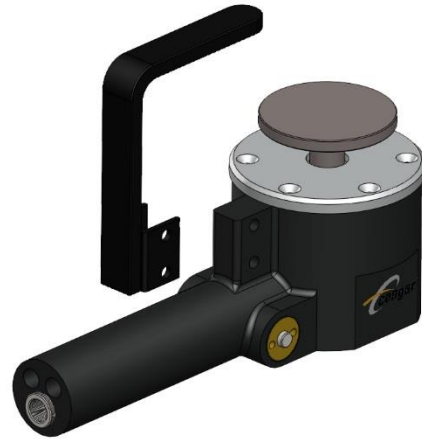

**4. Remove the top plate screws.**

Using an Allen key, remove the six top plate screws.

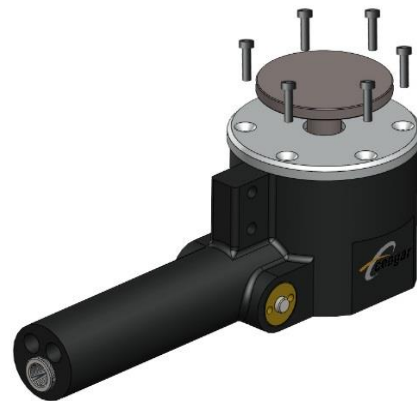

### 5. Remove the piston assembly.

Once the top plate screws have been removed the piston assembly should lift out of the Pallet Spreader body.

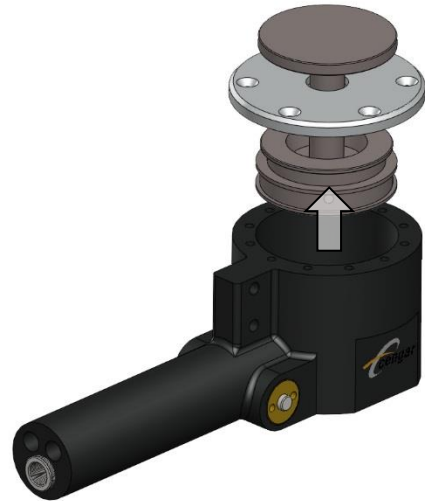

### 6. Remove the Circlip.

Using a pair of circlip pliers, remove the circlip from the bottom of the piston assembly.

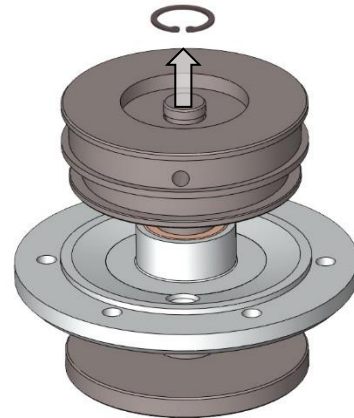

### 7. Remove the wear strip.

The wear strip is located on the larger groove of the piston. To remove this simply pull free.

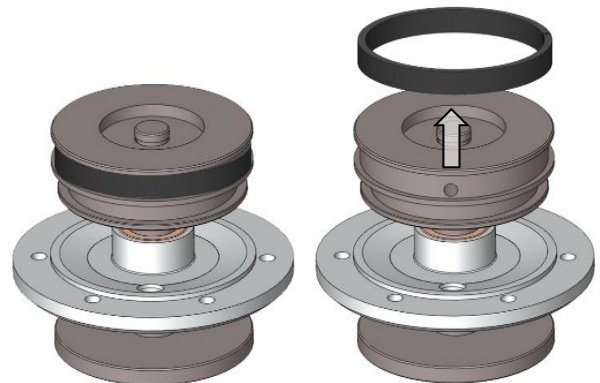

### 8. Remove the Selok pin.

Using a 4mm pin-punch, lightly tap the Selok pin from inside the piston assembly.

**Note:** The two holes in the piston slightly differ in size. The Selok pin should be removed from the larger hole.

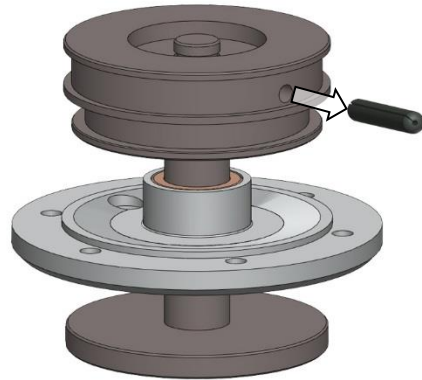

### 9. Remove the piston.

Once the Selok pin has been removed, the piston should come free from the assembly.

Removing the piston makes it easier to remove the piston seal.

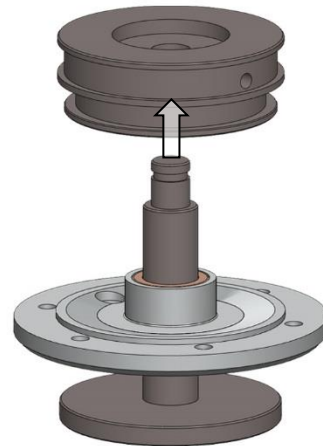

### 10. Remove the old piston seal.

Turn the piston upside down and using a small Allen key or screwdriver lightly prise the piston seal from the piston.

**Note: When using tools to remove the piston seal take care not to damage the piston.**



### 11. Replace the piston seal.

Replace the new piston seal on to the piston.

Make sure that the seal is not twisted and the cut-out is facing downwards when the piston is upside-down.

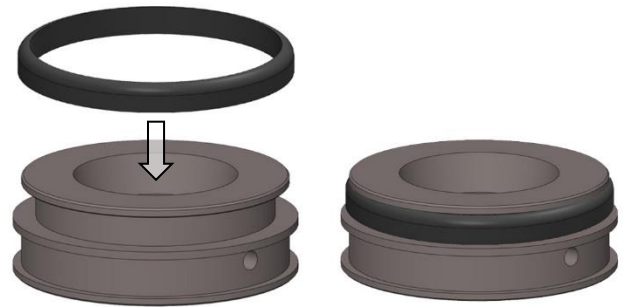

### 12. Replace the piston.

Return the piston to the position as shown in the image and replace it on to the piston assembly.

**Note: The hole for the Selok pin should be at the top.**

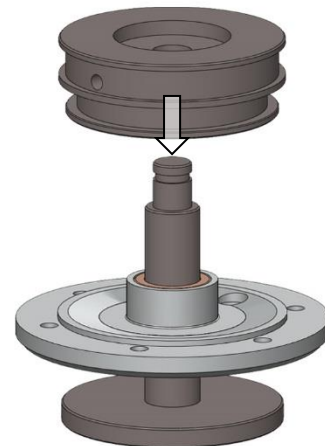

### 13. Replace the Selok pin.

Place the Selok pin in the larger hole and lightly tap back into place using a 4mm pin punch and hammer.

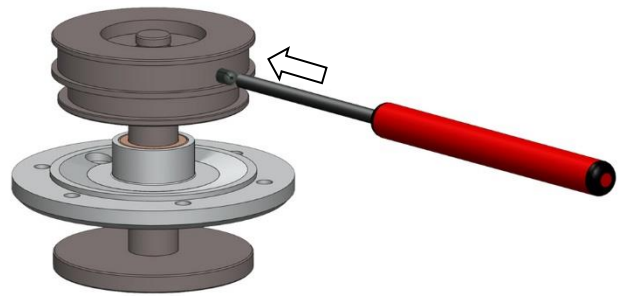

### 14. Ensure Selok pin is central.

The Selok pin should be placed central in the assembly.

To ensure the correct position lightly tap the pin with the pin punch from both sides until satisfied that the pin is central.

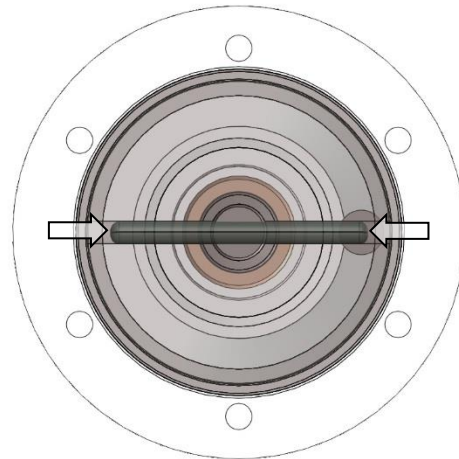

### 15. Replace the Circlip.

Replace the circlip at the bottom of the piston assembly to additionally secure the piston in place.

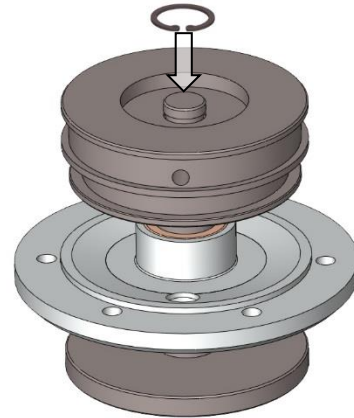

### 16. Replace the wear strip.

Replace the wear strip on the piston so that it covers the larger groove.

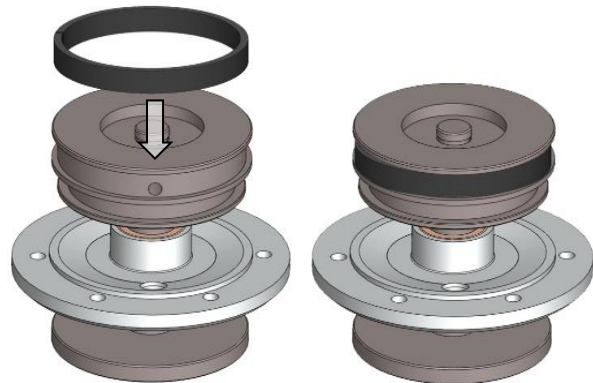

### 17. Apply oil to the piston assembly.

Apply oil to the piston assembly before placing back into the Pallet Spreader body.

**Note: Pneumatic tools require regular oiling to prevent problems and machine failures.**

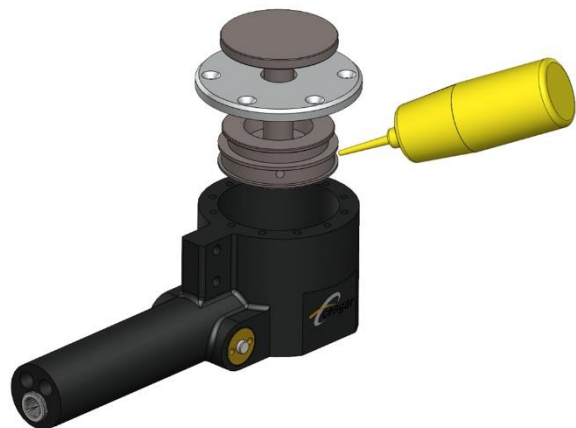

### 18. Replace the piston assembly.

The piston assembly can now be returned back into the bore of the Pallet Spreader.

Place the assembly into the body as shown, with the piston at the bottom of the assembly.

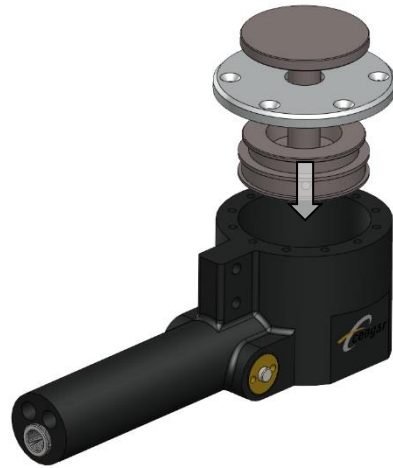

### 19. Apply a small amount of thread-lock to the top plate screws and screw into place.

Apply a small amount of thread-lock (Loctite 222 or similar) to each of the six countersunk top plate screws and screw into place.

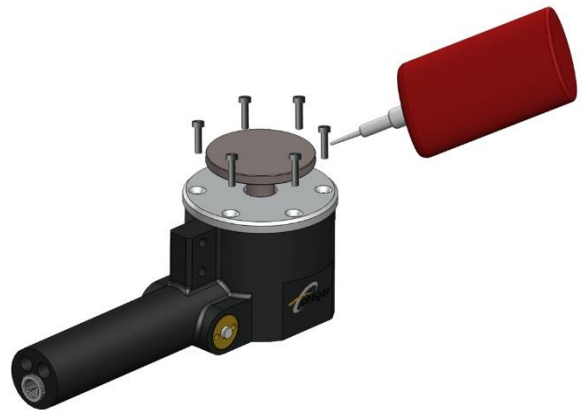

### 20. Apply lubricating oil through the rear air intake.

Apply oil through the air-line intake at the rear of the machine to ensure oil works its way through the machine and the Pallet Spreader is effectively lubricated.

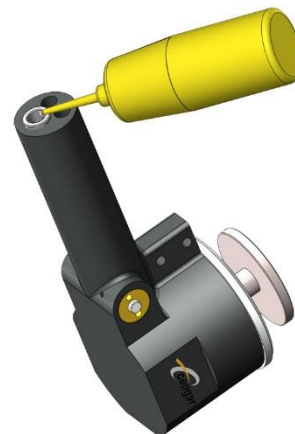



### 21. Attach the air-line adapter and air-line.

Attach the air-line adapter and air-line to the rear of the Pallet Spreader

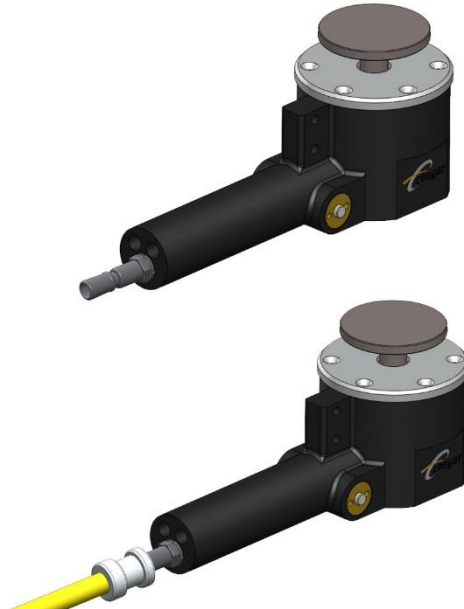

### 22. Activate and de-activate the pallet spreader to centralise and align the piston.

Using the trigger on the side of the machine, activate and de-activate the Pallet Spreader to ensure the piston is centralised in the bore.

**Note:**

**To activate – Press from left to right.**

**To de-activate – Press from right to left.**

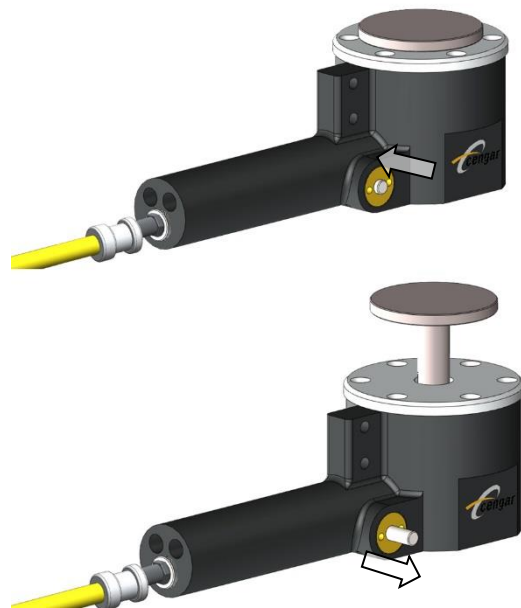

### 23. Tighten the screws until the top plate is secured with no escaping air.

To ensure no air is escaping through the top plate, tighten the top plate screws.

Tighten the screws in twos, working from opposite sides of the top plate.

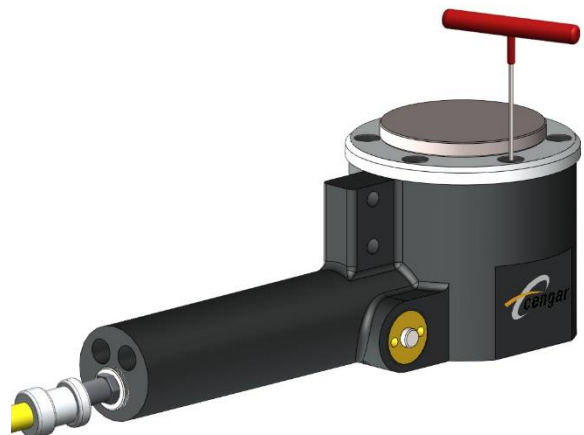

#### 24. Replace the board retainer.

Replace the board retainer on the Pallet Spreader.

**Note:** The board retainer is a safety device. Never use the Pallet Spreader to expand a pallet without this in place.

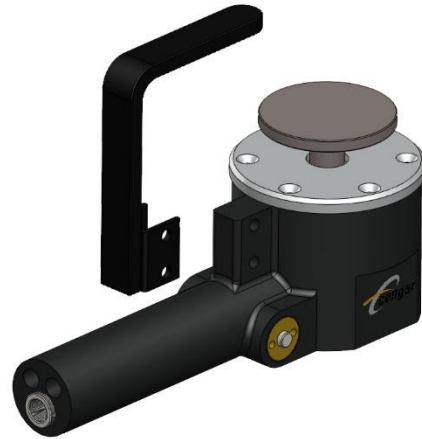

#### 25. Replace the lifting bracket.

Place the lifting bracket over the upper hole of the board retainer.

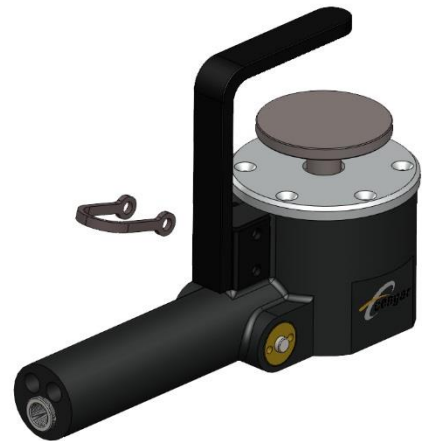

## 26. Replace the lifting bracket screws.

Replace the two lifting bracket screws to secure the lifting bracket and board retainer in place.

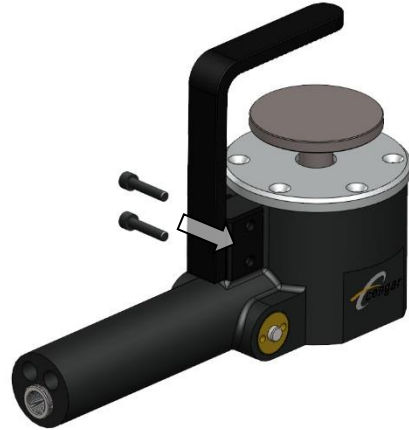

# PS2 Pallet Expander

Visit [www.cengar.com](http://www.cengar.com)  
for more information

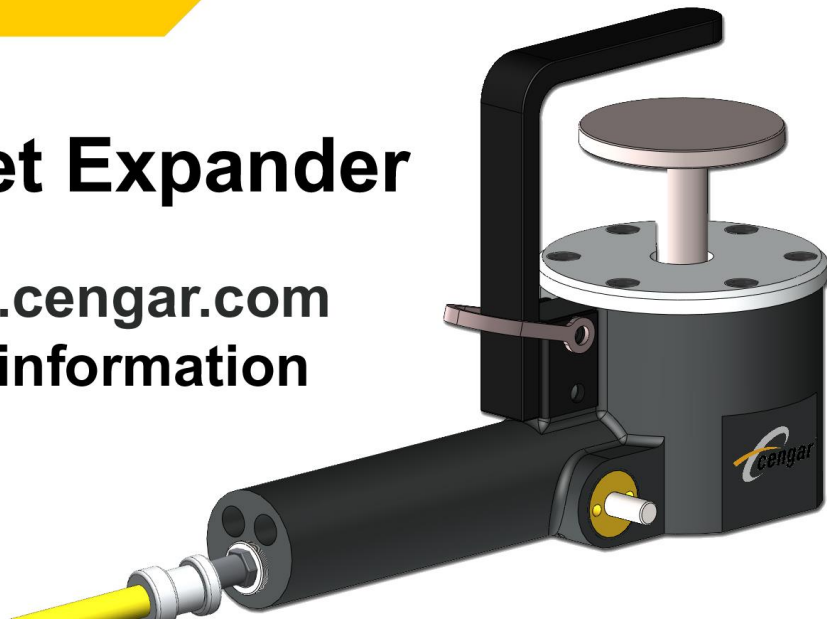

Cengar Ltd. Springfield Works, Saddleworth Rd. Greetland Halifax HX4 8LZ, U.K.  
Tel: +44 (0)1422 377904 Fax: +44 (0)1422 377161

[www.cengar.com](http://www.cengar.com) Email: [enquiries@cengar.com](mailto:enquiries@cengar.com)